

WMP-171/172

Medical Grade All-in-one Solution
The best component for medical device



Web camera

: USB2.0 1.3M module

TV tuner

: PCI type
(NTSC/PAL/SECAM)

Wireless LAN

: MiniPCI interface 802.11b/g
with build in antenna

Features

- 17" medical grade panel PC
- Medical certification compliance (EN60601-1 / UL60601-1)
- Anti-bacteria coating
- High Performance Intel Core 2 Duo Mobile Processor
- Supports PCI Expansion
- HDD Anti-vibration mechanism
- IP65(IP65 at front panel) / IPX1 compliance
- WebCAM (Optional)
- Supports 802.11b/g Wireless Solution with internal antenna (Optional)
- Fanless Design (WMP-172)
- Lower Noise Fan Design (WMP-171)

System

CPU	Intel® Core™ 2 Duo 2.2G CPU (WMP-171) Intel® Celeron-M 2.0G CPU (WMP-171) Intel® Core™ 2 Duo 1.06G CPU (WMP-172)
FSB	533MHz / 800MHz
Chipset	Intel® GME965 chipset + ICH8M
BIOS	Award BIOS, ACPI supported
VGA	Intel® GME965 integrated VGA (X3100)
DVI	One DVI 29 pin output
Audio	Realtek ALC286 Audio Codec, 2+2 watts power amplifier
LAN	Realtek RTL8111B Gigabit Ethernet x 2
Memory	Two Dual Channel DDR2 SODIMM socket supports up to 4GB (Default: 512M)
I/O	ICH8M
Serial ATA	Port x 1 with 150 MB/s transfer rate x 1
USB	8 USB 2.0 ports (4 ports in the rear I/O region, 2 ports with on-board pin headers, and 2 reserve for WebCAM and Touch screen.)
WDT	Generates system reset; 256 segments, 0, 1, 2...255 sec.

Expansion

PCI x1	PCI 2.2 expansion slot x 1
PCMCIA	PCMCIA Type I/II 32-bit CardBus slot x 1
Mini-PCI	32-bit Mini-PCI socket x 1

External I/O

VGA	DB-15 x 1
DVI	DVI output x 1
Audio Jack	3.5mm phone jack connector (Line-in, Line-out, and Mic-in)
USB	USB 2.0 x 4
COM	DB-9 x 3
KB/Mouse	PS/2 Connector x2 for keyboard/mouse
LAN	RJ45 x2 for Gigabit Ethernet
Power	DC-In connector x 1
Switch	Reset key
Speaker	2W x 2
Front Bezel	LED Indicator/ Hot Key (Power Button/ Audio adjustment +/- / brightness +/-)

Mechanical & Environmental

Power Input	DC12V-28V
Power Adapter	AC 90 ~ 264V / 47 ~ 63 Hz / DC output 12V
Operation Temperature	0~40°C
Storage Temperature	-20~80°C
Operation Relative Humidity	10%~90%, non-condensing
Storage Relative Humidity	10%~90%, non-condensing
Dimensions	420 x 360 x 83mm (W x H x D)
Weight	7 kg without AC adapter
Mounting	VESA Mount 75/100mm
IP65 at front / IPX1 compliance	
Kensington lock hole	

Display and Touch

Panel	17", 400 nits
Touch	Resistive type

Storage

HDD	2.5" SATA HDD drive bay x 1 (with anti-vibration mechanism) (Default: 80G)
CF	1 x bootable Compact Flash slot for CF type I/II storages (Optional CF card)

Fully-integrated I/O

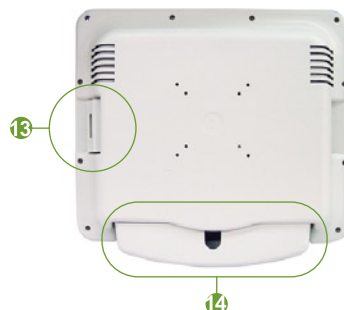
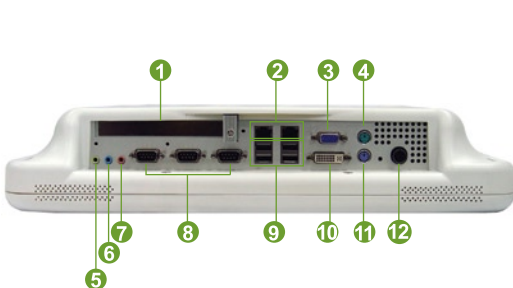

- ① PCI Slot
- ② Giga LAN
- ③ VGA
- ④ PS2 Mouse
- ⑤ Line-out
- ⑥ Line-in
- ⑦ Mic
- ⑧ RS232
- ⑨ USB
- ⑩ DVI
- ⑪ PS2 K/B
- ⑫ Power DC-in
- ⑬ Rubber cover
- ⑭ I/O cover

